

DSA25

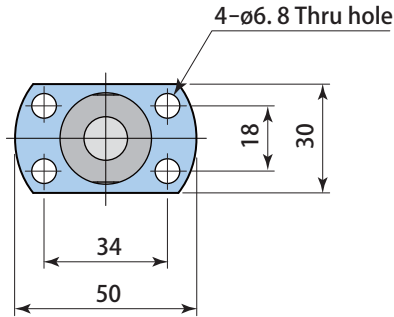

**DSA32
DSA38
DSA50**

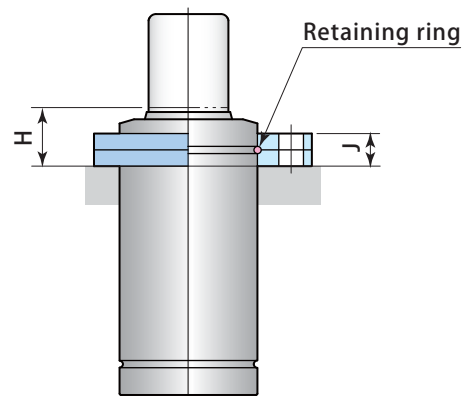
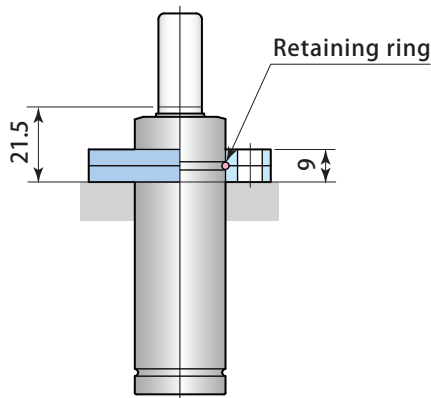
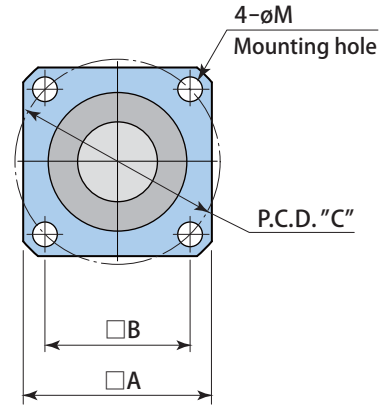

Note1 : Only **FC** flange is available for DSA25.

Note2 : Flanges are designed with sufficient strength to accommodate the loading.

(The flange should support the load by its full mounting face, and should be mounted by 4 screws.)

Gas spring model	Flange model	A mm	B mm	C mm	H mm	J mm	M mm	Mass kg
DSA25	DJF025-FC	Refer to the above sketch						0.08
DSA32	DJF032-FS	45	35	49.5	17	9	6.8	0.10
DSA38	DJF038-FS	52	40	56.5	17	9	6.8	0.12
DSA50	DJF050-FS	70	56.5	80	24	13	9	0.30

Flange mounting screws are not furnished.

DSA25

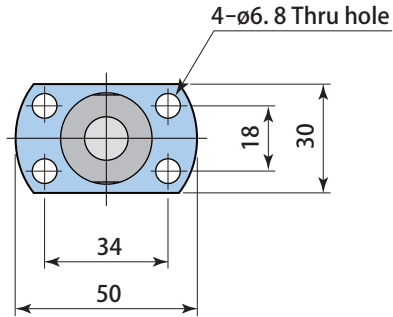

DSA32
DSA38
DSA50

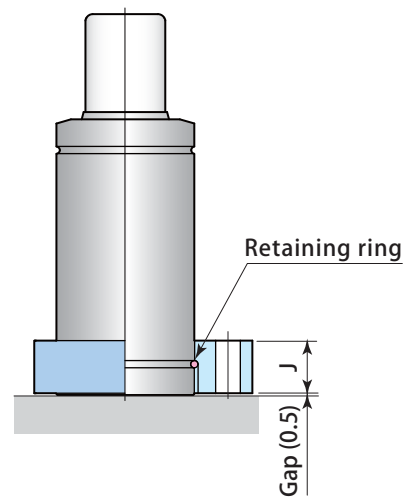
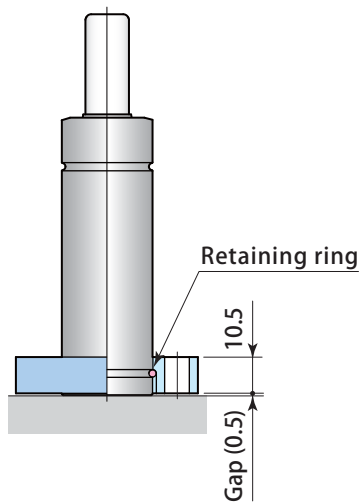
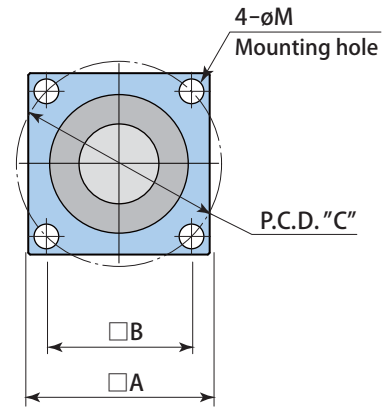

Note : The cylinder should be backed up fully at the bottom face.

Gas spring model	Flange model	A mm	B mm	C mm	J mm	M mm	Mass kg	
DSA25	DJF025-BM	Refer to the above sketch						0.06
DSA32	DJF032-BM	45	35	49.5	15	6.8	0.12	
DSA38	DJF038-BM	50	40	56.5	15	6.8	0.13	
DSA50	DJF050-BM	70	56.5	80	20	9	0.39	

Flange mounting screws are not furnished.