

Spring pressurizing type accumulator. After separation from oil supply source, keeps the in-circuit pressure stable against temperature fluctuation.

Model	WPB2-1	WPB2-2	WPB2-3	WPB3-1	WPB3-2	WPB3-3	WPB4-1	WPB4-2	WPB4-3
Working Pressure	2 MPa			3 MPa			4 MPa		
Discharge Volume	2.0 cm ³	4.0 cm ³	8.0 cm ³	2.0 cm ³	4.0 cm ³	8.0 cm ³	2.0 cm ³	4.0 cm ³	8.0 cm ³
Absorption Volume	1.2 cm ³	2.4 cm ³	4.8 cm ³	1.2 cm ³	2.4 cm ³	4.8 cm ³	1.2 cm ³	2.4 cm ³	4.8 cm ³
Pressure Transition per 1cm ³	0.55 MPa	0.38 MPa	0.19 MPa	0.50 MPa	0.33 MPa	0.17 MPa	0.43 MPa	0.29 MPa	0.14 MPa

Model	WPB5-1	WPB5-2	WPB5-3	WPB6-1	WPB6-2	WPB6-3	WPB7-1	WPB7-2	WPB7-3
Working Pressure	5 MPa			6 MPa			7 MPa		
Discharge Volume	2.0 cm ³	4.0 cm ³	8.0 cm ³	2.0 cm ³	4.0 cm ³	8.0 cm ³	2.0 cm ³	4.0 cm ³	8.0 cm ³
Absorption Volume	1.2 cm ³	2.4 cm ³	4.8 cm ³	1.2 cm ³	2.4 cm ³	4.8 cm ³	1.2 cm ³	2.4 cm ³	4.8 cm ³
Pressure Transition per 1cm ³	0.41 MPa	0.27 MPa	0.16 MPa	0.89 MPa	0.61 MPa	0.36 MPa	0.84 MPa	0.59 MPa	0.34 MPa

Proof pressure WPB2,3,4 : 7MPa WPB5,6,7 : 15MPa Ambient temperature : 0~70°C Fluid used : ISO-VG32 equivalent normal operation oil
 Type of mounting (last symbol of model definition GS : Manifold Side Mount Type GB : Manifold Bottom Mount Type T : Piping Type)
 There is a type available that fluorine rubber (Viton) is adopted at the sealing portions for protection against chlorine coolant.
 (Symbol V. Example : model WPB □-□□-V, This is not a heat proof specification.)

model **WPB**□-□□ ※Built-in Filter not included

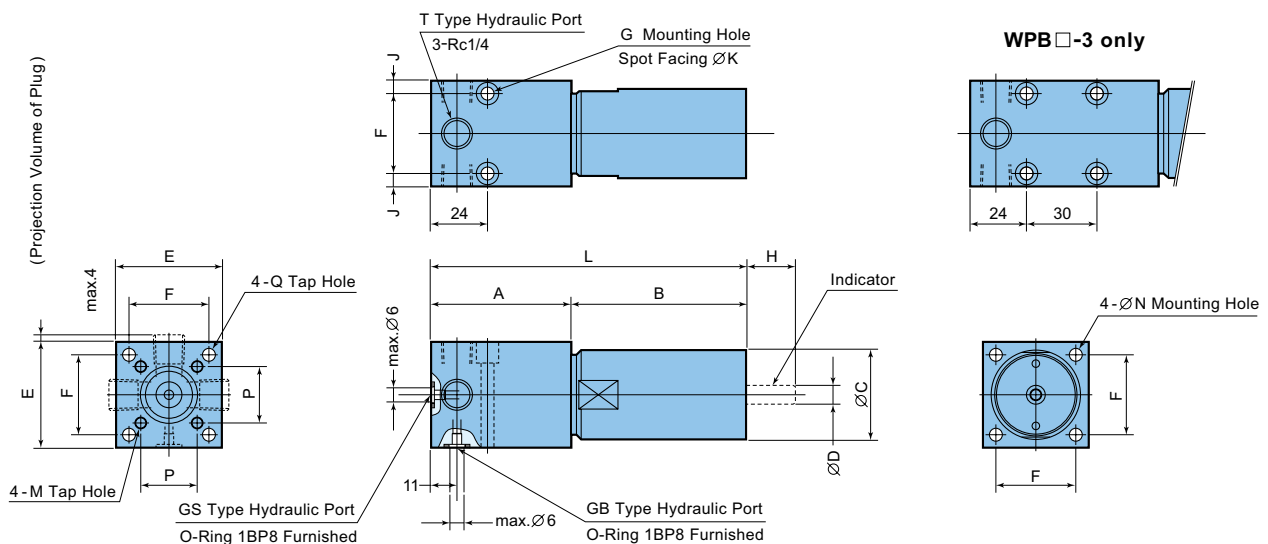

Model	A	B	C	D	E	F	G	max.H	J	K	L	M	N	P	Q
WPB2/3/4	-1	49	46				2-Ø5.5	10.5			95	M5 Depth 10	5.5	24	—
	-2	59.5	74.5	38	8	45	2-Ø5.5	21	5.5	Ø9.5 Depth 9	134				
	-3	80	151				4-Ø5.5	41.5			231				
WPB5/6/7	-1	49	70				2-Ø6.8	10.5			119	—	6.8	—	M8 Depth 16
	-2	59.5	105	42.7	10	50	2-Ø6.8	21	6	Ø11 Depth 11	164.5				
	-3	80	186				4-Ø6.8	41.5			266				

NOTE: Blind plug (2 pcs for T Type, 3 pcs for GS/GB Types) are furnished. Mounting bolts are not furnished.

PERFORMANCE DIAGRAM WPB □-1

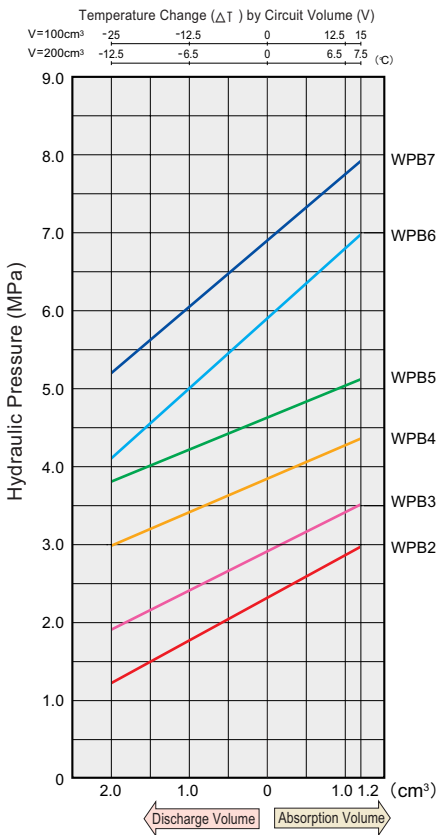

WPB □-2

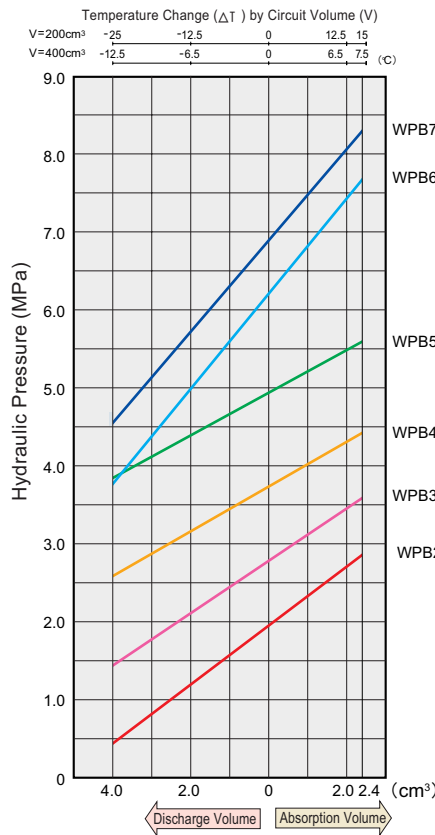

WPB □-3

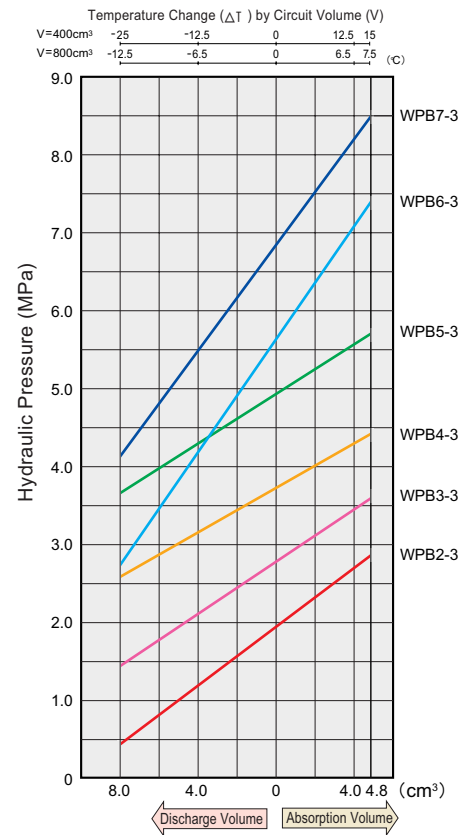

NOTE: All figures on the diagrams are theoretical.

MODEL SELECTION

CONDITIONS

Work Clamp Used	CLG0.9 X 4 pcs	Piping	Inside $\varnothing 6 \times 0.5 \times 4$ pcs
Hydraulic pressure (P)	3.5MPa	Expected temperature drop	20°C

SELECTION PROCEDURE

- To select working pressure of WPB
 In case the hydraulic pressure is 3.5MPa, you choose model WPB3, not WPB4.
 As temperature is basically going to drop during the use, you need to choose a model of which discharge volume is larger.
- To work out Total Circuit Volume
 Clamp's Cylinder Capacity : $12.6 \times 2.65 \times 4 = 134 \text{ cm}^3$
Number of Clamp
Clamp Stroke
Cylinder Area (Clamping side)
 Volume in the pipes : $0.28 \times 50 \times 4 = 56 \text{ cm}^3$
 Total Circuit Volume : $134 + 56 = 190 \text{ cm}^3$
- To work out volume of WPB
 Find a volume transition out of the formula on the right.
 $\Delta V = 190 \times 20 \times 7.8 \times 10^{-4} = 3.0 \text{ cm}^3$
 Out of calculation above, you choose model WPB3-2 of which discharge volume is 4.0 cm³
- How to check hydraulic pressure & residual discharge volume after temperature change.
 Find out of Performance Diagram on the right.
 After temperature change, hydraulic pressure (P1) goes down to 2.5MPa.
 Residual discharge volume becomes 3.1 cm³.
 The force of built-in spring fluctuates. It is safer to have a margin of residual discharge volume after temperature change. Marginal volume is as under.
 WPB □-1: about 0.5 cm³ WPB □-2: about 1.0 cm³ WPB □-3: about 1.5 cm³
- Select a type of mounting.

Volume Transition Calculation Format

$$\Delta V = V \times \Delta T \times \alpha$$

- ΔV : Volume Transition (cm³)
- V : Total Circuit Volume (cm³)
- ΔT : Temperature Change (°C)
- α : Thermal Expansion Coefficient (7.8×10^{-4})

