

DIMENSIONS

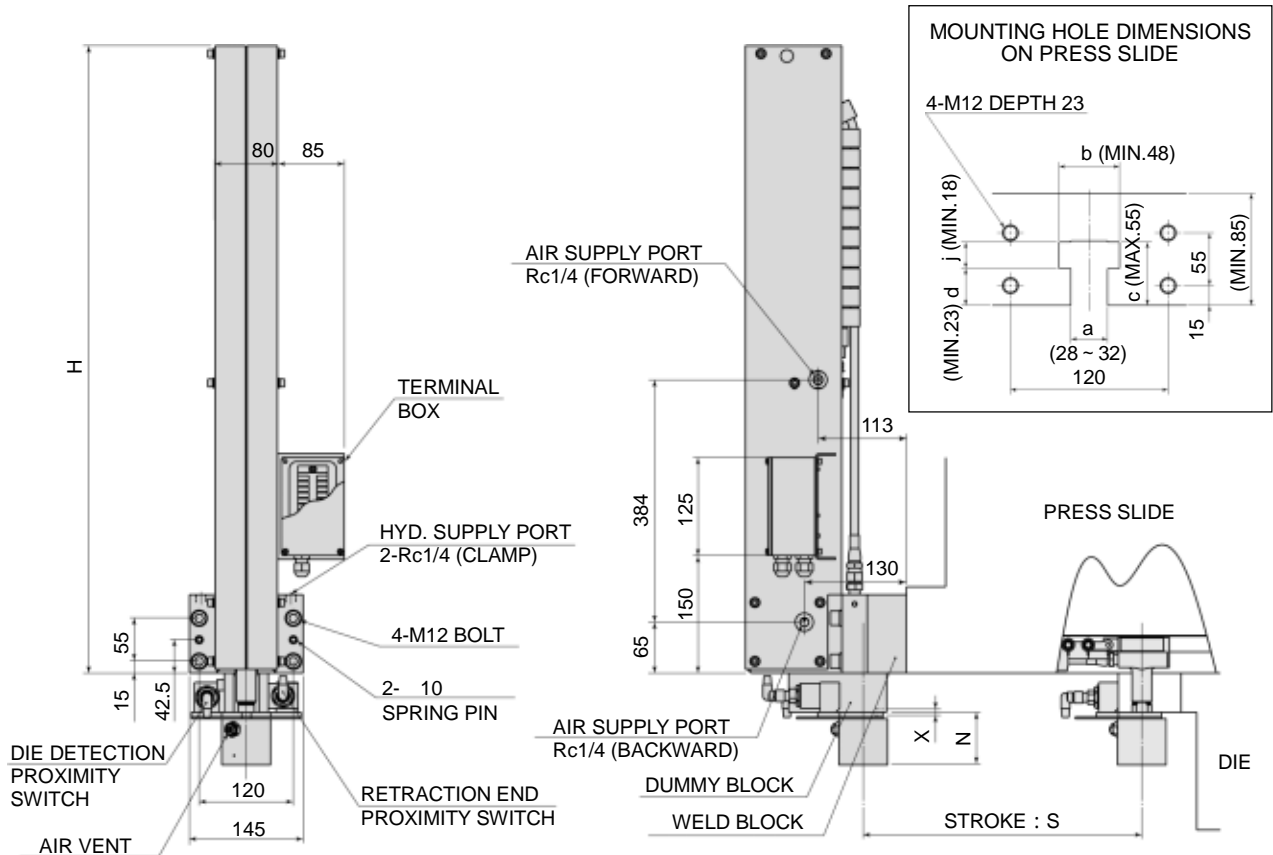

(mm)			
STROKE : S	H	STROKE : S	H
400	700	900	1200
500	800	1000	1300
600	900	1100	1400
700	1000	1200	1500
800	1100	1300	1600

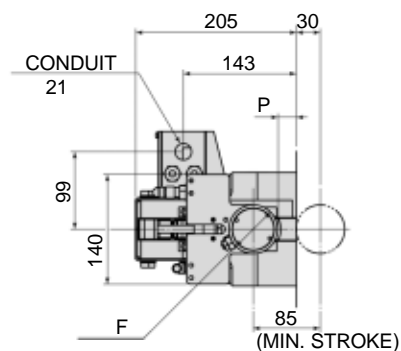

SPECIFICATIONS

CLAMP MODEL	TXD 4	TXD 6	TXD 10
CLAMPING FORCE *1	4 tonf { 39.2 kN, 4.41 USton }	6.3 tonf { 61.7 kN, 6.94 USton }	10 tonf { 98.0 kN, 11.0 USton }
CLAMPING STROKE : X	8 mm (Full Stroke)		
SLIDING STROKE : S	400 ~ 1300 mm, every 100 mm		
SLIDING FORCE *2	20 kgf { 196 N }		
SLIDING SPEED	4 ~ 6 m / min		
DIMENSIONS	F	62 mm	78 mm
	N	67.2 mm	73.2 mm
	P	24 mm	16 mm

* 1: Hydraulic pressure 250 kgf/cm² { 24.5 MPa, 3560 psi }

* 2: Air pressure 4 kgf/cm² { 0.39 MPa, 57 psi }