

Model TKB is a retractable lever type clamp. The unique wedge construction ensures a strong holding force, even with oil pressure failure.

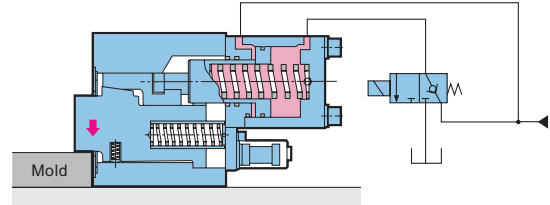

**FIXED**



**UNFIXED**

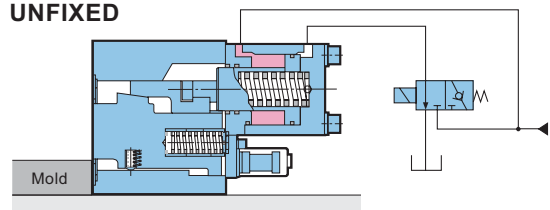

**SPECIFICATIONS** (TKB  —  N : NPT port )

MODEL		TKB16	TKB25	TKB40	TKB50
Fixing Force (US ton)	At hydraulic pressure 1987 psi	5.5	8.8	15.4	19.8
Holding Force (US ton)	At hydraulic pressure 1987 psi	17.6	27.6	44.1	55.1
	At no hydraulic pressure (0 psi)	2.2	3.3	5.5	9.9
Full Stroke : X	(in)	0.177	0.177	0.217	0.217
Fixing Stroke : Y	(in)	0.079	0.079	0.098	0.098
Safety Stroke : Z	(in)	0.098	0.098	0.118	0.118
Cylinder Capacity	Fixed (in <sup>3</sup> )	17.33	28.07	52.42	87.14
	Unfixed (in <sup>3</sup> )	10.56	16.90	30.94	56.81
Weight	(lb)	83.8	147.7	286.6	551.2

■ Proof pressure : 2973 psi    ■ Working temperature range : 32~176°F

**DIMENSIONS**

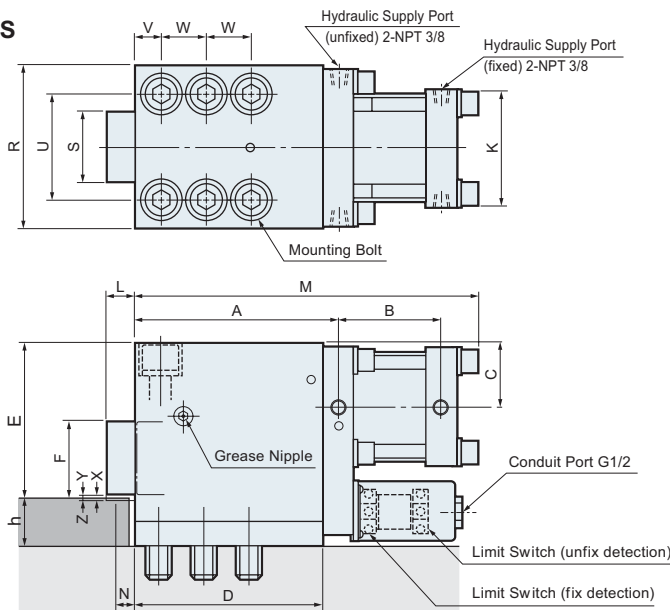

**LIMIT SWITCH SPECIFICATION (YAMATAKE)**

Limit Switch Model	BZ-2RD3000-T4-J	
Rated Voltage	AC250V	DC30V
Rated Current (Resistance Load)	15A	15A

MODEL	E	F	L	M	N	R	S	U	V	W	K	T	h	A	B	C	D
TKB16	5.512	2.953	1.295	12.205	0.787	5.709	2.559	3.858	0.866	1.535	4.134	M20	MIN.1.575	7.106	3.898	2.283	6.516
TKB25	6.693	3.228	1.287	14.508	0.787	6.890	2.992	4.646	1.063	1.929	5.039	M24	MIN.1.969	8.701	4.350	2.717	8.051
TKB40	7.874	3.898	1.496	17.091	0.984	8.465	3.543	5.709	1.260	2.362	6.102	M30	MIN.1.969	10.315	5.079	3.189	9.547
TKB50	10.827	5.315	1.701	21.768	1.181	10.630	4.528	7.480	1.575	3.150	7.756	M39	MIN.1.969	12.796	7.047	4.075	11.811