

AIR COUPLER SOCKET MODEL (FEMALE)
model **WVP-2WSN**



AIR COUPLER PLUG MODEL (MALE)
model **WVP-2WPN**

Air coupler particularly designed for machine tools.

- Minimized intrusion of chips and coolant by making the area of contacting portion smallest possible.
- Built-in filter prevents the intrusion of foreign substances.

Max. Working Pressure	1.0 MPa
Proof Pressure	1.5 MPa
Orifice area	12.5 mm ²
Fluid used	Air
Allowable misalignment	± 1mm
Allowable gradient	less than 0.2°
Reaction force	201 N per 1 MPa air pressure Max. spring force 86 N at 0 MPa air pressure
Ambient temperature	0 ~ 70°C
Mass	WVP-2WSN: 135g WVP-2WPN: 115g

NOTE : Air supply should be done after connection.

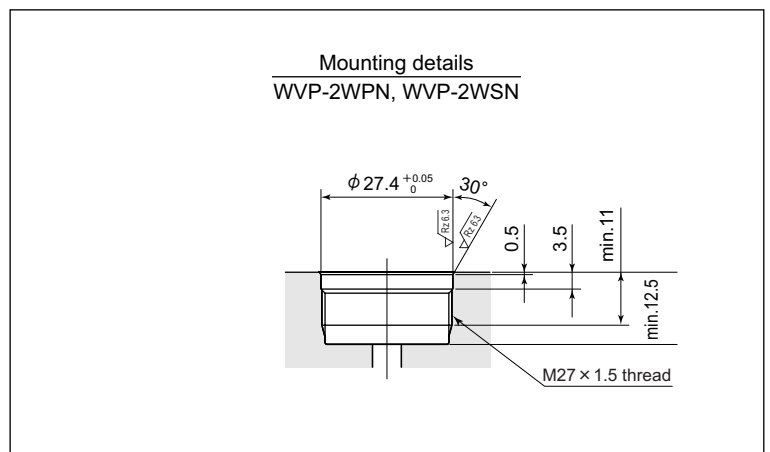
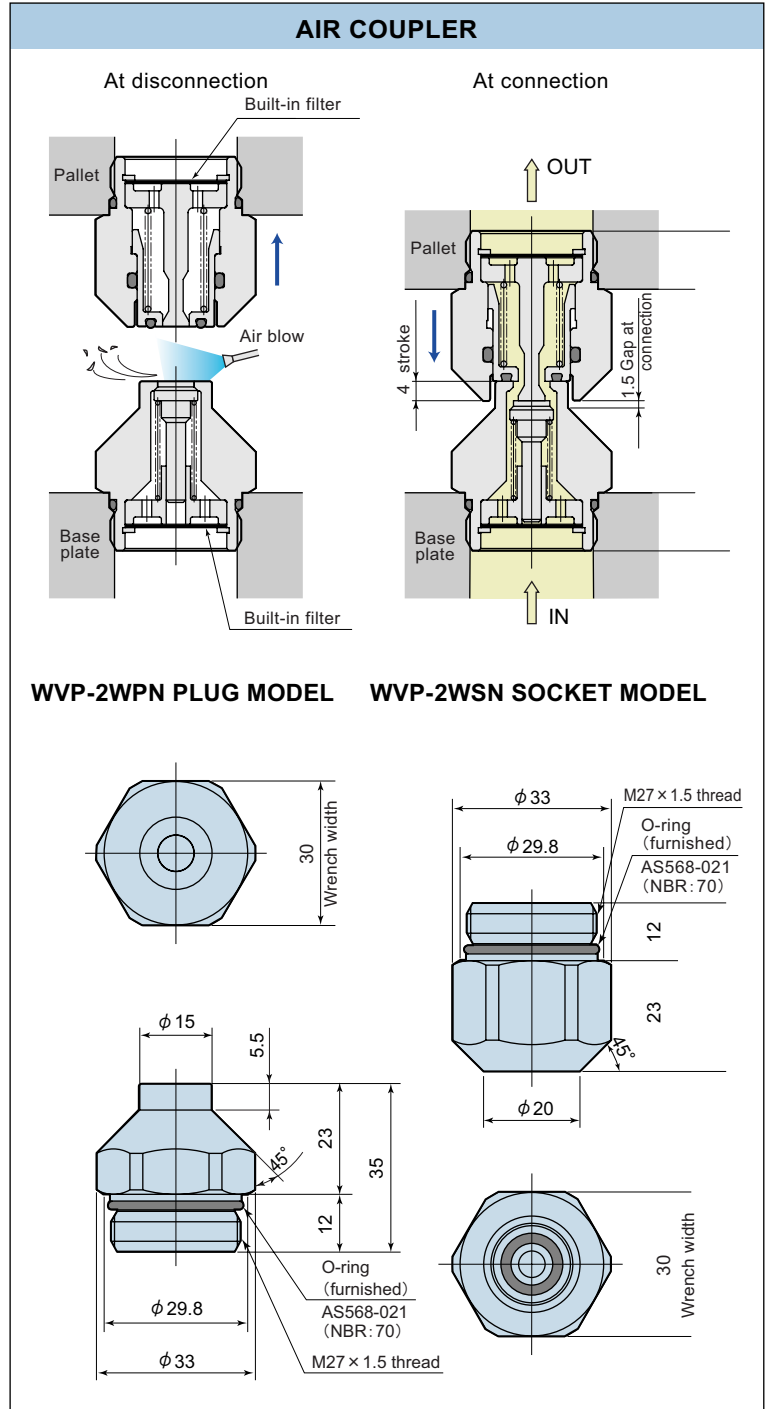

Caution In Use

1. When using a model that can connect/disconnect under pressure, be sure to carry out a sufficient air bleeding out of the circuit at the time of installation. If insufficient, the spill amount at disconnection may become larger.
2. Avoid connecting when the cutting chips or coolant liquid are attached at the tip of coupler. In such cases, be sure to carry out an air-blow before connection.
3. Before connecting the couplers, be sure to remove the burrs from the threaded portions of manifold or piping holes and clean inside the piping by flushing to completely put the chips away. As the filter is not built-in at the piping port side of each coupler, the intruded chips may scratch the seal portion to cause a possible oil leakage.
4. Forwarding force of coupler should be larger than the reaction force. The reaction force remains while coupled.
5. Guide or stopper are not prepared at the coupler body. They need to be provided at your end.

Reaction force calculation example

● Conditions

Hydraulic	2 circuits with double acting clamp (both 5 MPa) Coupler model : WVP-2HPL × 2, WVP-2HSL × 2
Air	1 circuit for landing detection (0.3 MPa) Coupler model : WVP-2WPN, WVP-2WSN

● Reaction force at clamping

Clamp circuit

$$\text{Spring force } 157(\text{N}) + \text{Hydraulic pressure } 5(\text{MPa}) \times 154 = 927(\text{N})$$

Unclamp circuit

$$\text{Spring force} = 157(\text{N})$$

Air circuit

$$\text{Spring force } 86(\text{N}) + \text{Air pressure } 0.3(\text{MPa}) \times 201 = 146(\text{N})$$

● Total reaction force

$$\text{Hydraulic coupler } 927(\text{N}) + 157(\text{N}) + \text{Air coupler } 146(\text{N}) = 1230(\text{N})$$